

Stab.

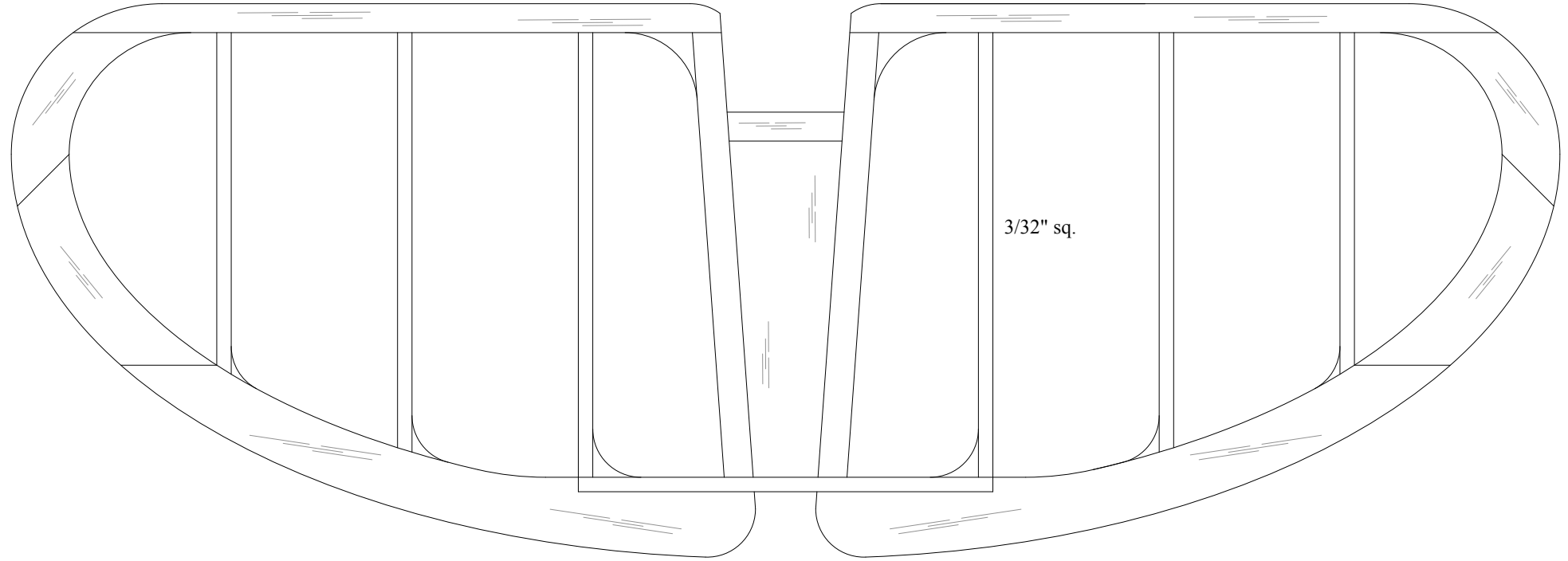

All 3/32" thick construction to allow for good profile shaping of components without losing too much strength.
Could be constructed from 1/16" stock to save weight (remember to alter size of slot in fuselage for stab. in this case)

Sub Fin

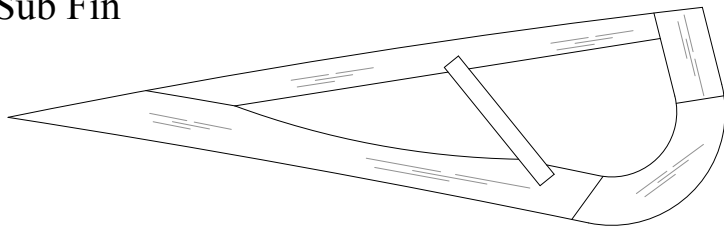

Fin

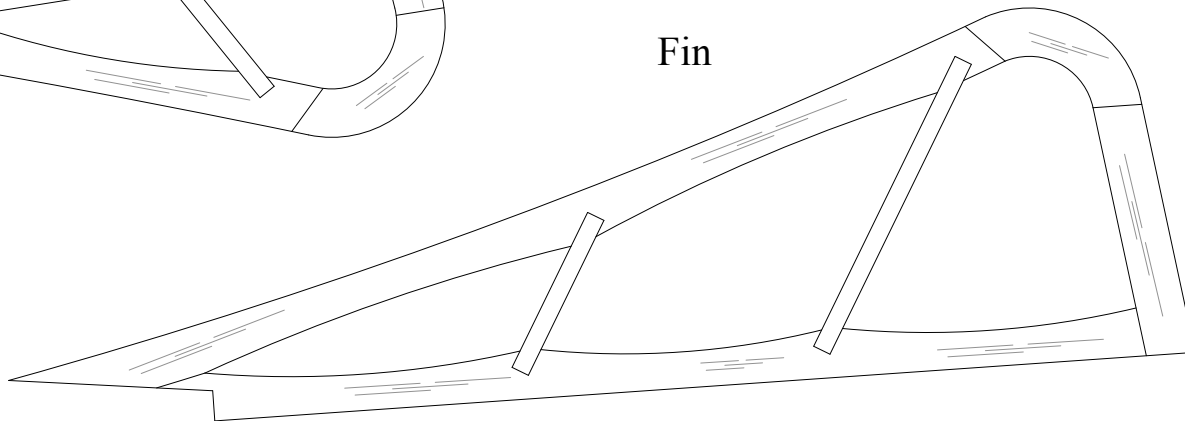

Why-6

Designed by
Andrew Michaelsmith

Drawn by Russ Lister
© 2006

SECTIONS
AT STATED
FORMER

* NOTE

Some may find the fuselage sheeting difficult.
Infilled sheeting or carved block could be substituted
according to personal preference,
particularly around the wing root and cockpit areas.

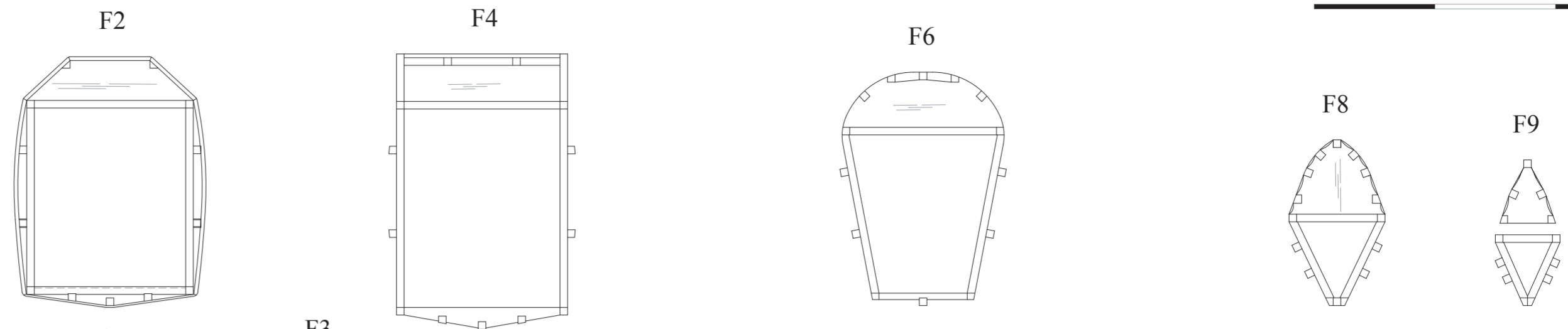

Sand away between
stringers as shown
for an improved
tissue line

All sheeting 1/32" balsa
faired into fuselage
towards the edges*

All stringers are 1/16" sq.

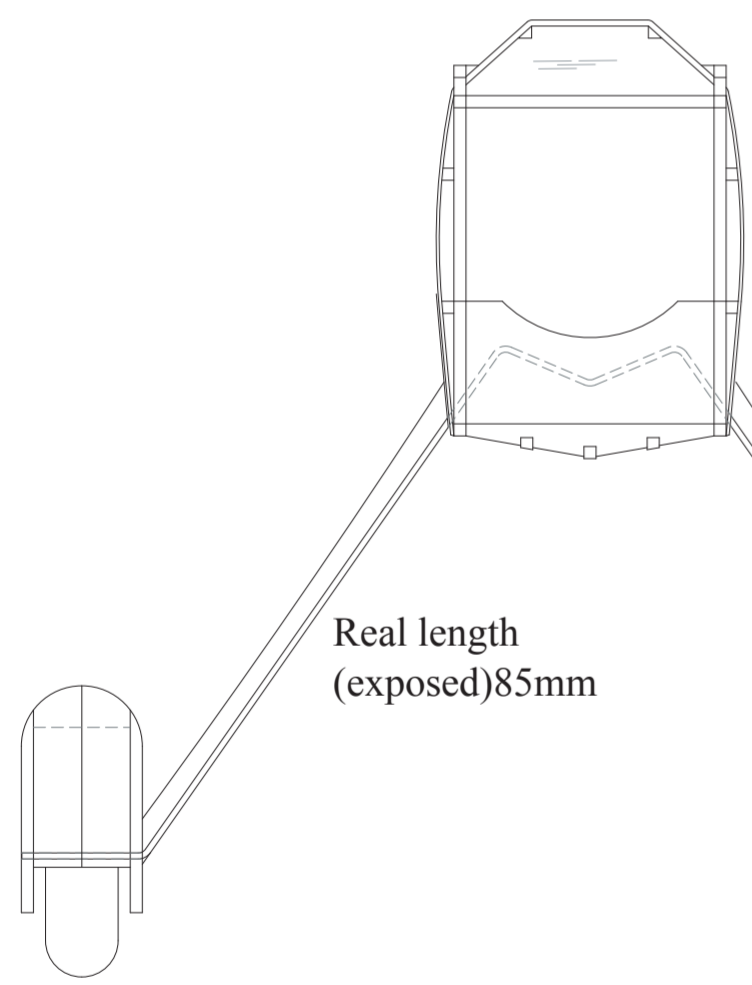

Nose block from
solid balsa with
plug to suit
aperture in F1

UC wire sandwiched
between F3 and 1/8"
hard balsa

SPATS
Outer: 1/16"
Centre: 2 x lams 1/4"

UC legs

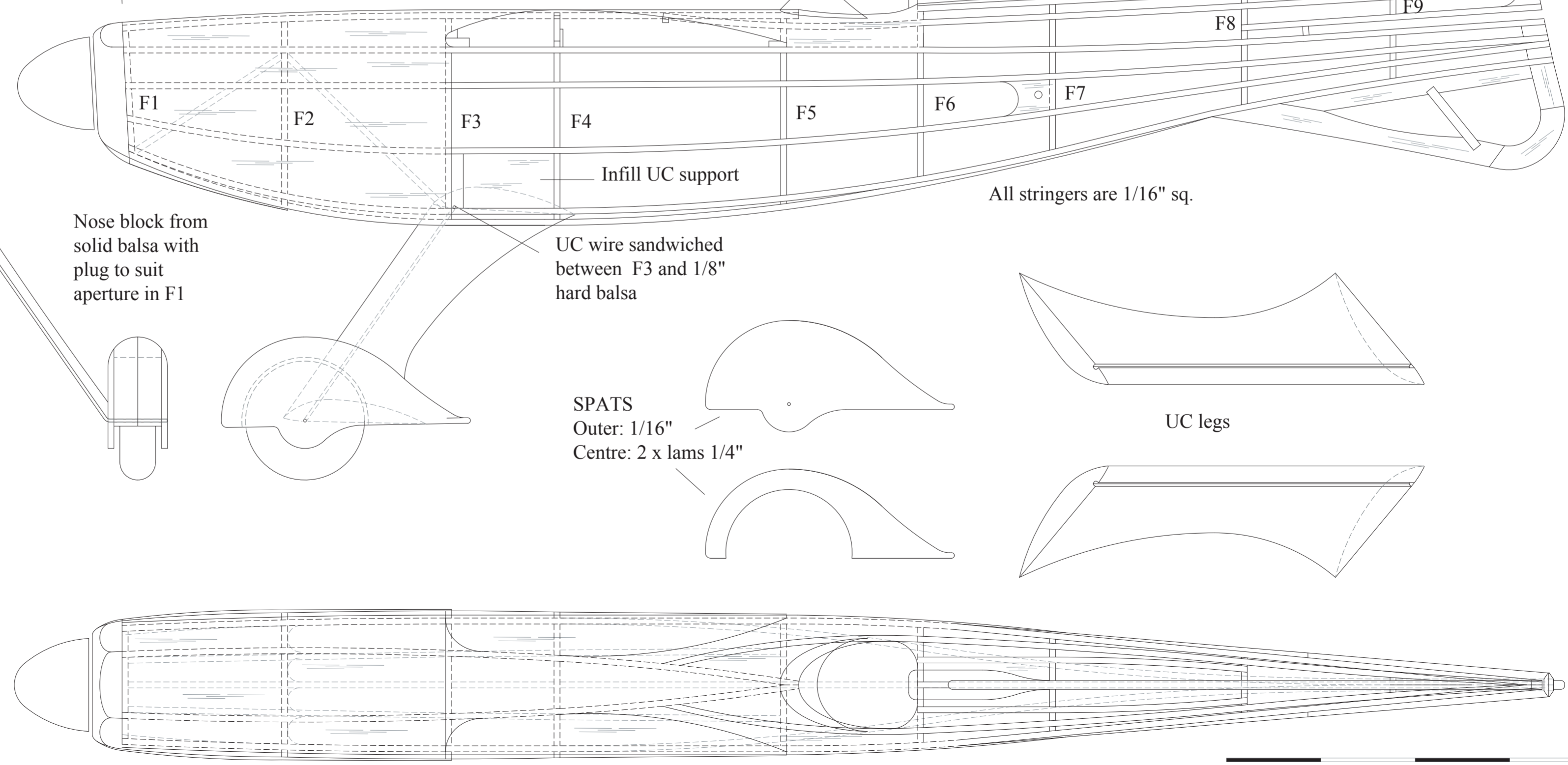

Why-6

Designed by
Andrew Michaelsmith
Drawn by Russ Lister
© 2006

Starboard Wing

Leading edge upper and lower 3/32"

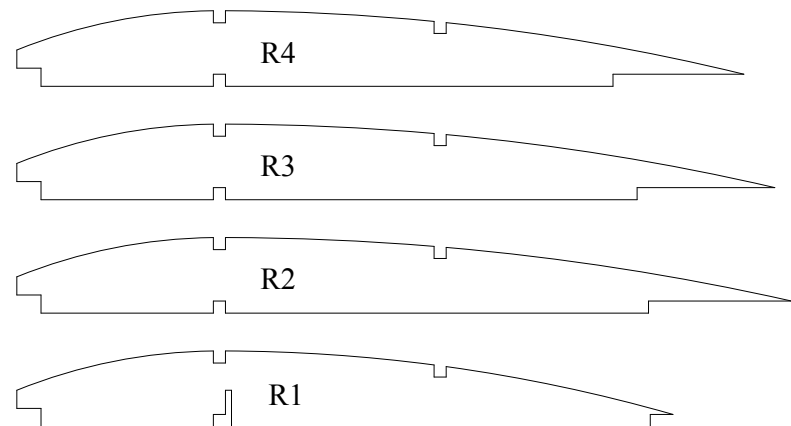
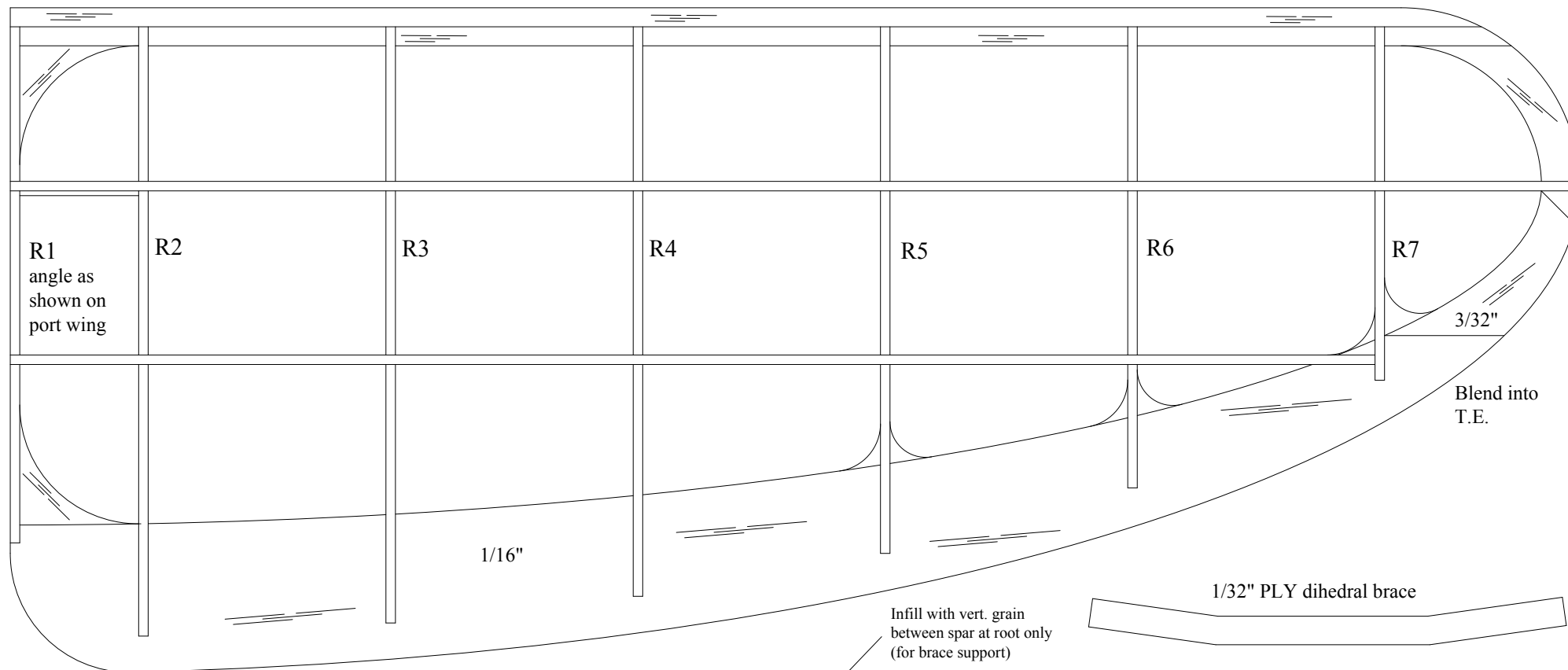

Section at Root Rib

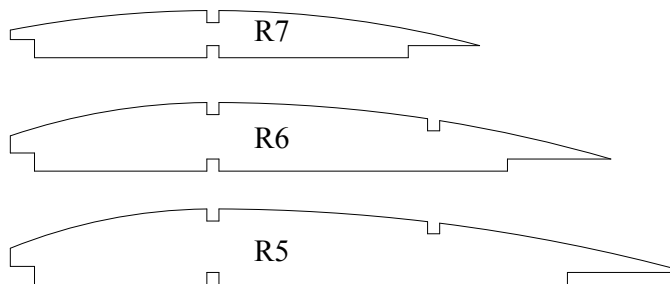

Why-6
Designed by
Andrew Michael Smith
Drawn by Russ Lister
© 2006

Port Wing

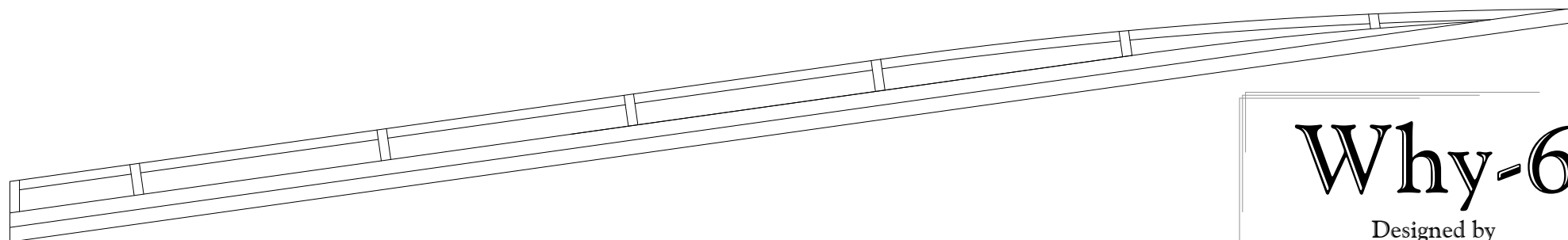
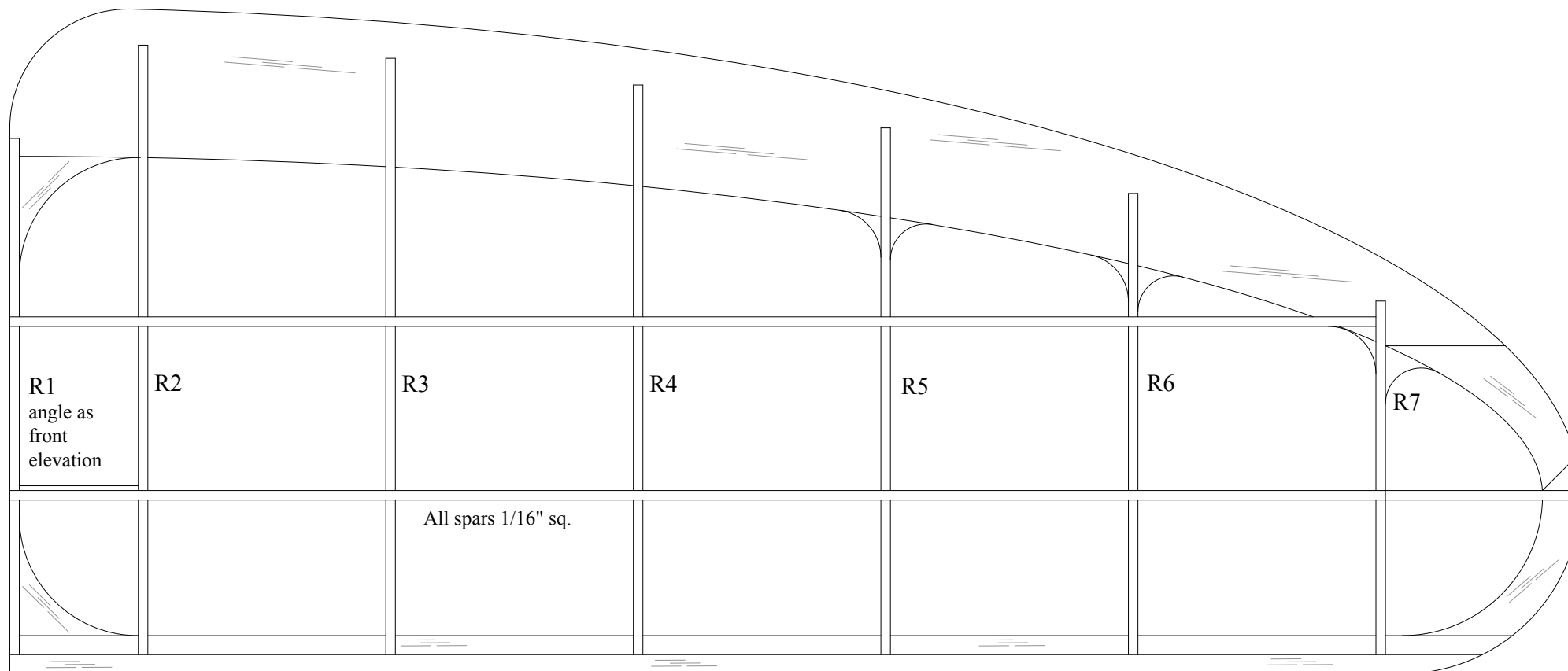

Why-6

Designed by
Andrew Michaelsmith

Drawn by Russ Lister

© 2006